



Twin Lakes

Twin Lakes
Twin Lakes









← McKay Rd.

← Progress Pkwy →



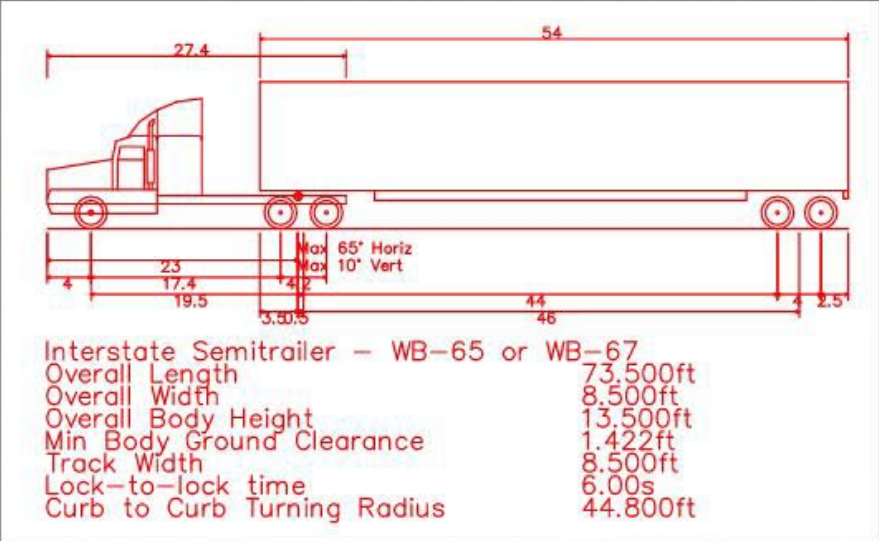

FROM I-74

Trk 9

NORTH

TO TWIN LAKES ADDITION

E McKay Rd

E McKay Rd

Progress Pkwy

Progress Pkwy

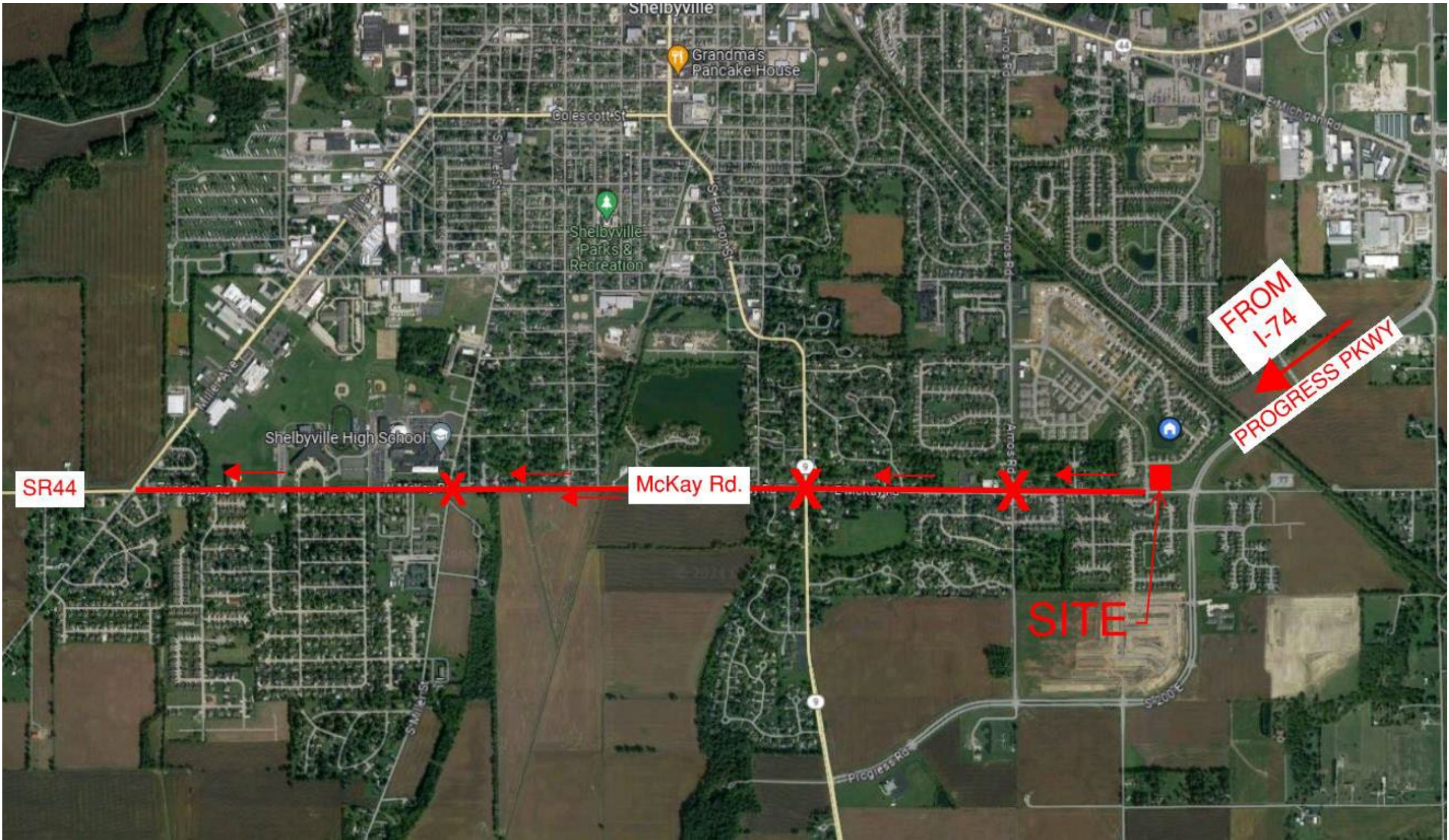

SR44

McKay Rd.

FROM I-74

PROGRESS PKWY

SITE

Grandma's Pancake House

Shelbyville Parks & Recreation

Shelbyville High School

Colescott St

Miller Ave

S Allison St

Amos Rd

E Michigan Rd

Progress Rd

SR200E

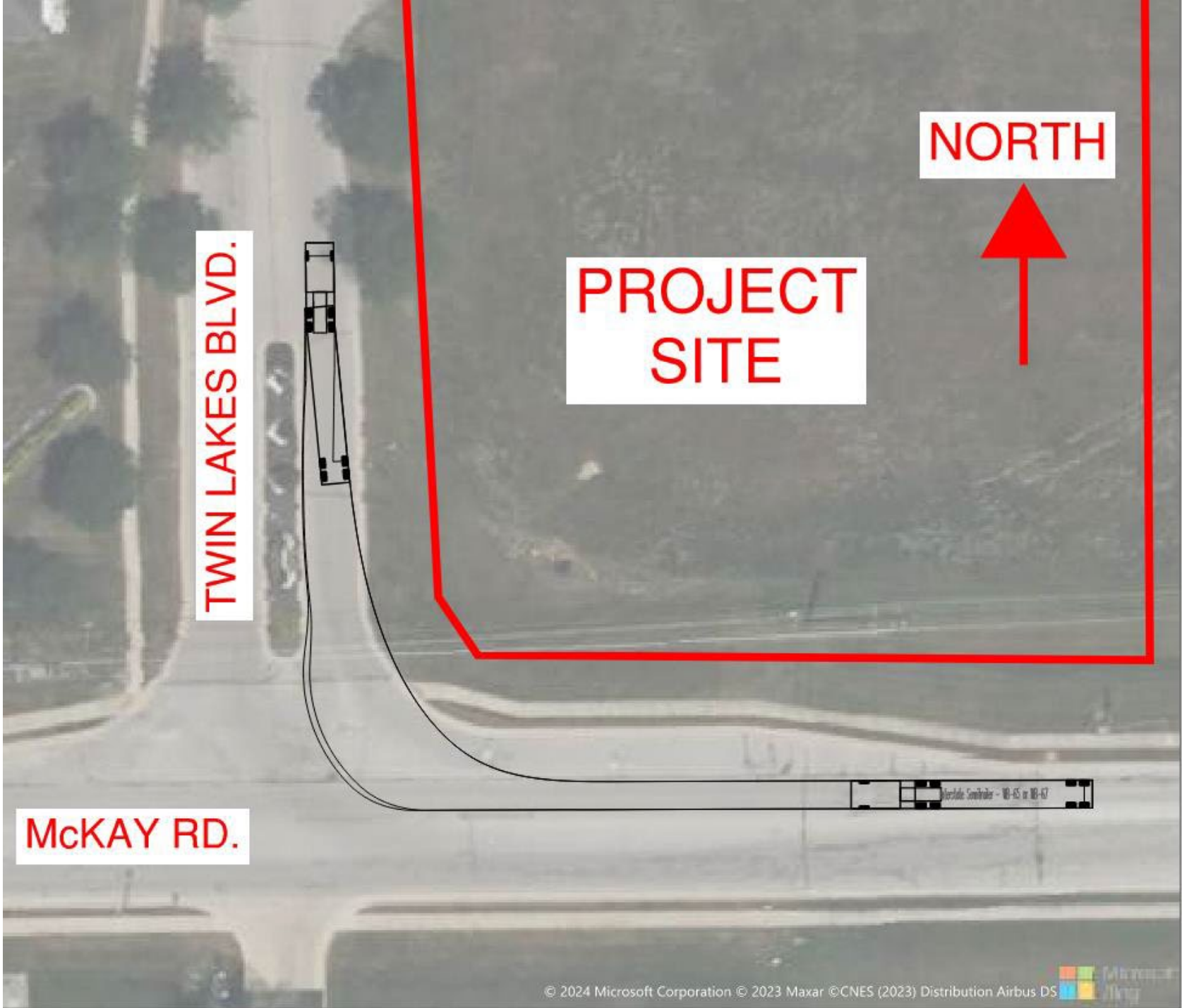

TWIN LAKES BLVD.

PROJECT SITE

NORTH

McKAY RD.

Merida Satellite - 10-45 to 10-67





Amos Rd.

FROM I-74

PROGRESS PKWY

McKay Rd.



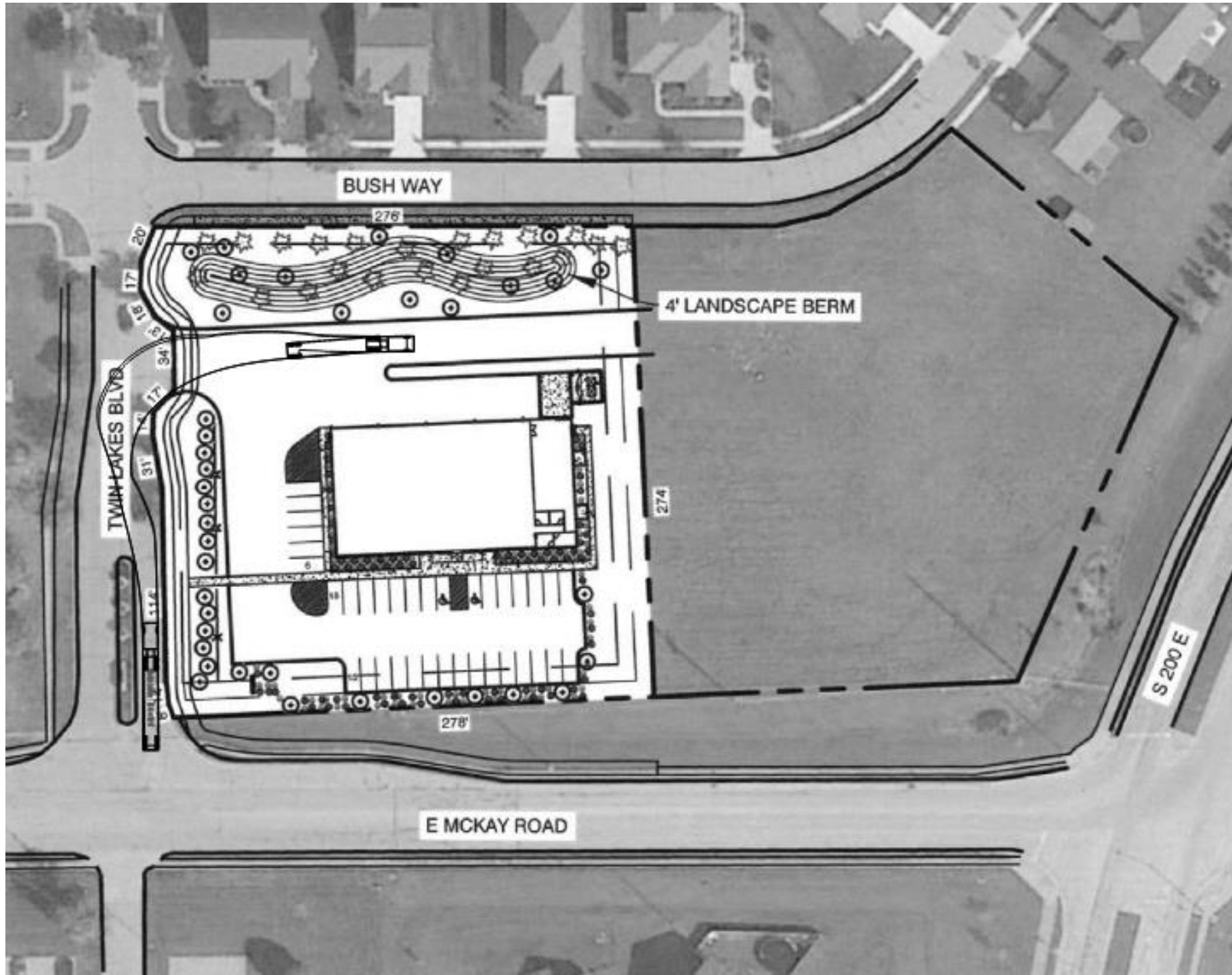

BUSH WAY

278

20

17

8

17

34

TWIN LAKES BLVD

SMALL SIGN

4' LANDSCAPE BERM

274

E MCKAY ROAD

278

S 200 E

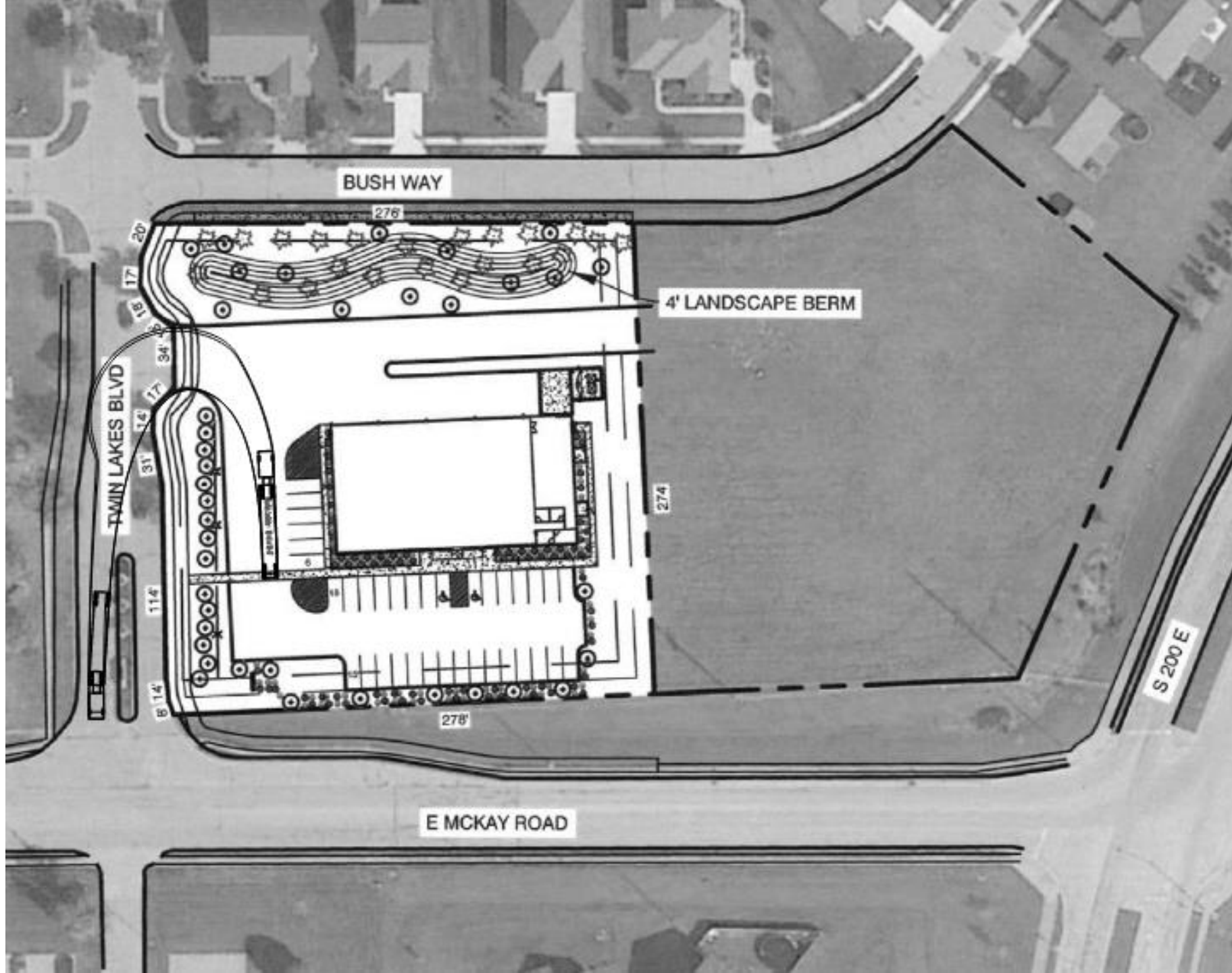

BUSH WAY

278

20

17

18

34

17

14

31

114

8' 14"

278'

4' LANDSCAPE BERM

274

S 200 E

E MCKAY ROAD

TWIN LAKES BLVD



Entrance and Drive Standards (ED)

5.15 ED-04: Non-residential Driveway Standards

This Entrance and Drive Standards (ED) section applies to the following zoning districts:



The following standards apply:

- A. Separation: The following tables shall regulate separation from a street and from another driveway or entrance.

Table ED-A: Driveway Separation Distances from Another Street (see "A" below in illustration)

Type of Facility	Arterial	Collector	Local
Right-in Only	300 feet**	100/200* feet	75/150* feet
Right-out Only	300 feet**	200 feet	150 feet
2-way Traffic	300 feet	250 feet	150 feet
2-way Traffic Entrance with Bidirectional Turn Lane on Street	300 feet	250 feet	150 feet

* First number is separation distance if drive upstream from an intersection/driveway and second number is separation distance if drive downstream from an intersection/driveway.
 ** Entrances on Arterial can be reduced by 100 feet when the speed limit is 20 to 30 MPH.

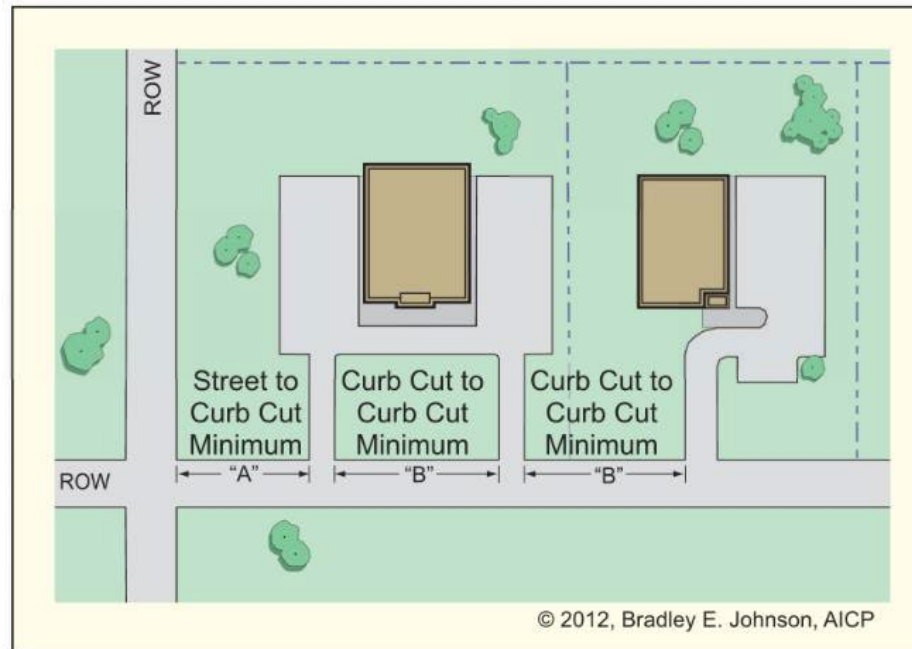

APPROACHING
CAR

NORTH END
OF ENTRANCE
ISLAND





NO LONGER
SEE THE CAR
OR ISLAND



HOURS OF IDEAL USE FOR THIS SITE

8:00 AM - 6:00 PM
(EX: Shelton Vet Clinic)



Yellow Business Hours
Blue - Residents be Around
Green - OVERLAP

HOURS ALLOWED PER ZONING

5:00 AM - 10:00 PM

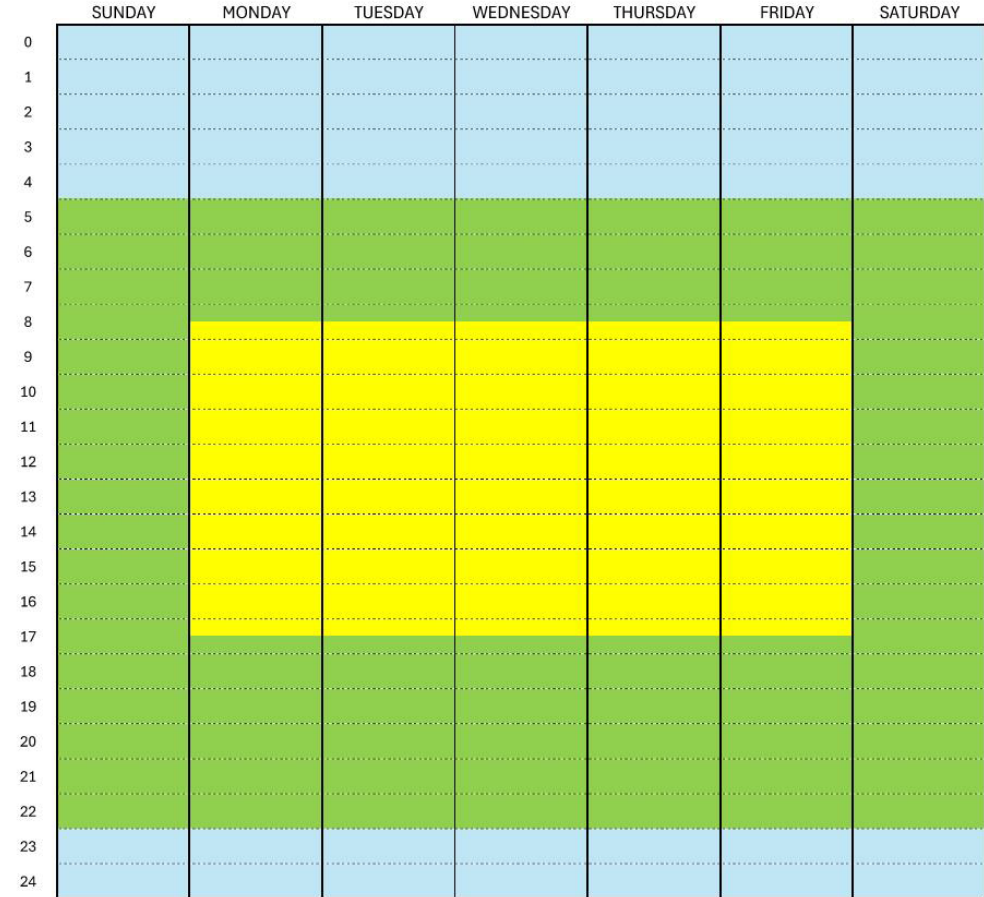

Yellow Business Hours
Blue - Residents be Around
Green - **OVERLAP**